

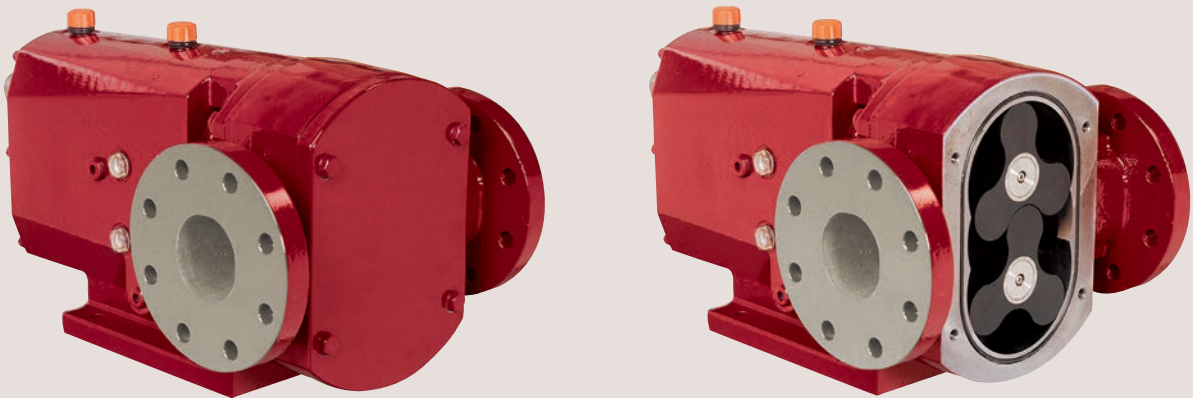

Series D

Rotary Lobe Pumps for industrial and sludge applications



SSP Series D ductile iron rotary lobe pumps fulfil positive transfer duties throughout industry where the use of stainless steel for pumphead components is not essential, within application areas such as Petrochemicals, Chemical, Paper, Paints and Polymers, Petfood, Chocolate and Sugar.

Series D pumps also cover a wide span of sludge transfer duties throughout the environmental and industrial waste treatment processes. Transfer duties include Primary, Secondary and Humus Desludging, Thickener, Digester and Filterpress Feed and Tanker loading.

User Benefits

- High efficiency
- Low energy consumption
- Compact size
- Robust construction
- Reversible operation
- Ability to pump abrasive media
- Cost effective easy maintenance

Series D pumps may offer lower installation costs compared with other pump technologies. In most cases this saving, when combined with low running and maintenance costs and easy access to the pumphead minimising downtime, results in a reduced lifecycle cost (LCC).



Series D pumps can be classified for use in potentially explosive atmospheres under the ATEX Directive 94/9/EC Group II, Categories 2 & 3, with temperature classification T1 to T4.

Operation

The positive displacement of the Series D pump is provided by non-contacting, contra rotating tri-lobe or bi-lobe rotors within a fully swept pump chamber. All Series D pumps are capable of bi-rotational flow without modification.

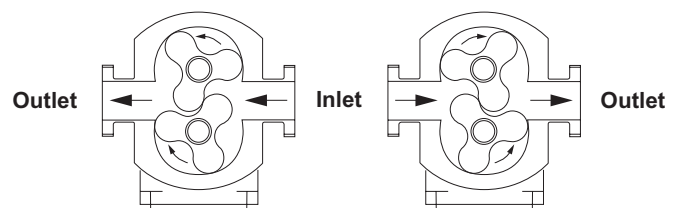

Performance

The Series D pump range has nine pump head displacements ranging from 0.79 litres/rev to 6.00 litres/rev.

- Flow rates up to 180 m³/h (up to 126 m³/h on sludge)
- Differential pressures up to 15 bar (up to 5 bar on sludge)
- Port sizes from 80 mm to 150 mm diameter

High Volumetric Efficiency - The Series D pump offers high efficiency transfer of low, medium and high viscosity pumped media. This important aspect of performance is achieved by maintaining high accuracy and repeatability of component part manufacture, thereby maximising shaft rigidity and minimising the effects of thermal expansion within the pump gearbox. This combination allows the optimum pump head geometry to be achieved which, in turn, maximises volumetric efficiency.

Basic Design

The Series D pump has a choice of 12 models, providing greater application flexibility and cost effective easy maintenance.

Pumphead– The pump casing is manufactured in ductile iron. The Series D in standard specification has tri-lobe rotors manufactured from ductile iron (for non- sludge applications) or a metal insert covered with urethane to give long term wear resistance. The urethane rotors can be supplied slotted, providing grit channels to improve rotor life.

Shafts - Manufactured from surface hardened carbon steel.

Gearbox - The Series D pump has a robust cast iron gearbox, which provides maximum shaft rigidity. Heavy duty taper roller bearing arrangements provide maximum support for both drive and auxiliary shafts.

Pump Model	Inlet and Outlet Connection Size (International Standards) mm	Displacement litres/rev	Differential Pressure bar	Maximum Speed		Weight Bare Shaft Pump kg
				rev/min	Sludge applications rev/min	
D4-0079-H15	80	0.79	15	750	-	110
D4-0095-H10	80	0.95	10	750	-	113
D4-0095-H05	80	0.95	5	500	350	113
D4-0140-H05	100	1.40	5	500	350	130
D5-0168-H15	100	1.68	15	600	-	170
D5-0200-H10	100	2.00	10	600	-	176
D5-0200-H05	100	2.00	5	500	350	176
D5-0290-H05	100 or 150	2.90	5	500	350	192
D6-0353-H15	150	3.53	15	500	-	281
D6-0420-H10	150	4.20	10	500	-	289
D6-0420-H05	150	4.20	5	500	350	289
D6-0600-H05	150	6.00	5	500	350	300

Note: Only Series D pump models rated at 5 bar differential pressure are suitable for sludge pumping.

Specification Options



Wear plates

Pump casings may be supplied fitted with hardened, replaceable wear plates (standard on sludge pumps). The wear plates can be replaced in situ with minimal pump dismantling.

Surface finish and coatings

For abrasive applications the ductile iron pumphead and rotors may be supplied with a tungsten carbide coating or other surface hardening treatment to increase wear resistance.

Bi-lobe rotors

Bi-lobe stainless steel rotors for highly viscous, abrasive applications such as magma and massecuite.

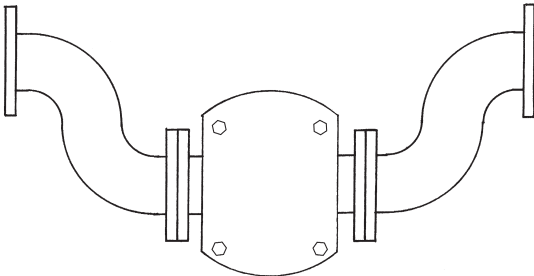

Motorised pump units

Pumps may be supplied fully motorised with fixed or variable speed drives including appropriate control systems if required, mounted on mild steel baseplates. In addition to electric motor drives, hydraulic, pneumatic, diesel or petrol powered prime movers can be fitted.

Pumped media seals

The optimum primary seal can be chosen to match the pumped media and duty conditions. Single or double mechanical seals include flushed variants. For arduous duties hard faced seal materials such as tungsten carbide or silicon carbide can be used. Cartridge mechanical seals are available for sludge and other similar difficult applications.

Packed glands offer a simple, low cost, and easy to maintain controlled leakage sealing arrangement.

Pumped media wetted elastomers are EPDM, NBR, FPM or PTFE.

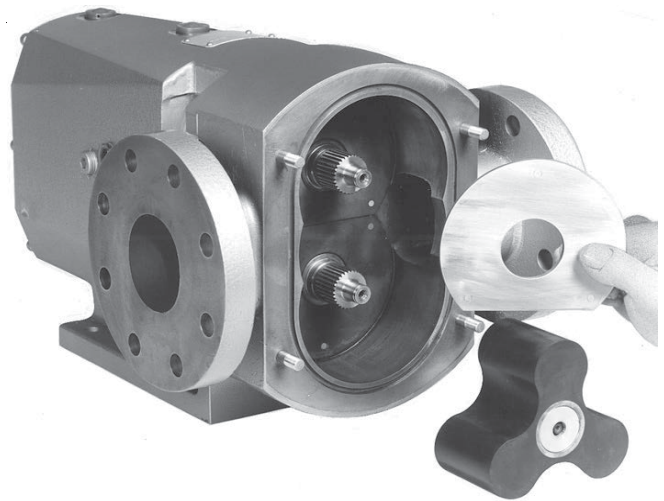

Connections

Pump casings are supplied with integral cast flanged inlet and outlet connections to all major standards including ASA/ANSI150, BS4504/DIN2533, BS10E and more.

On models D4-0095-H05 and D4-0140-H05, the flanged connections may be fitted with priming adaptors.

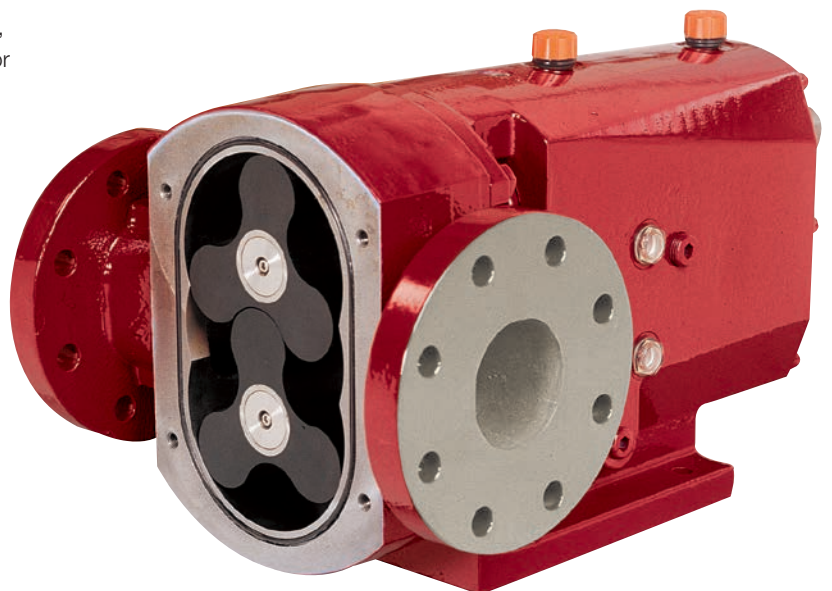

Bareshaft Pump Dimensions

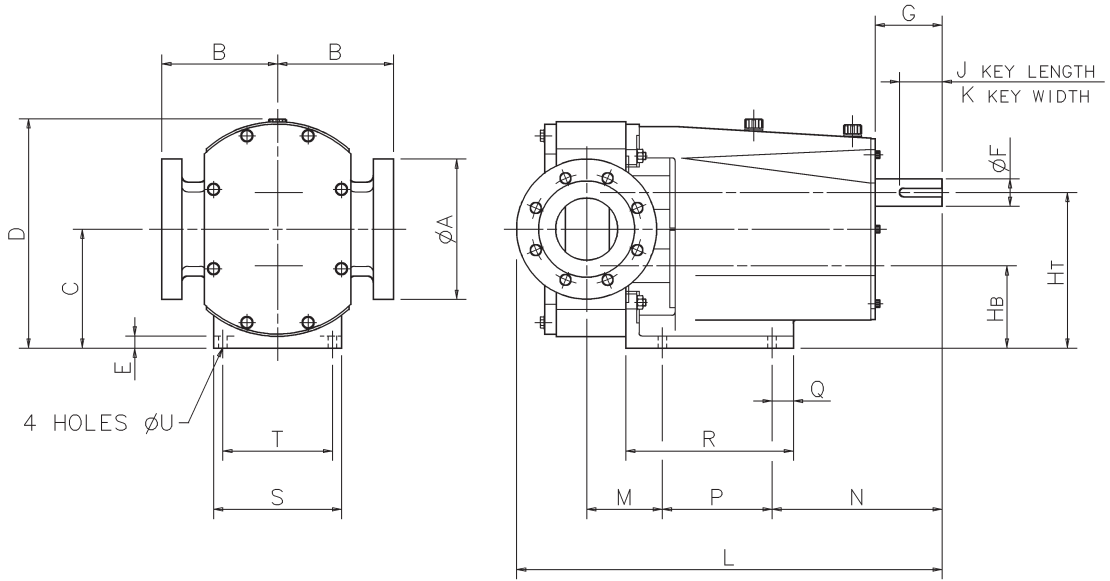

All dimensions in mm

Pump Model	A	B	C	D	E	F	G	HB	HT	J	K	L	M	N	P	Q	R	S	T	U
D4-0079-H15	80	170	163	307	20	38	80	115	211	63	10	593	118	225	150	35	255	184	150	14
D4-0095-H10	80	170	163	307	20	38	80	115	211	63	10	597	122	225	150	35	255	184	150	14
D4-0095-H05	80	170	163	307	20	38	80	115	211	63	10	597	122	225	150	35	255	184	150	14
D4-0140-H05	100	170	163	307	20	38	80	115	211	63	10	628	138	225	150	35	255	184	150	14
D5-0168-H15	100	190	195	371	20	45	110	135	255	70	14	692	118	279	180	35	275	210	180	14
D5-0200-H10	100	190	195	371	20	45	110	135	255	70	14	699	125	279	180	35	275	210	180	14
D5-0200-H05	100	190	195	371	20	45	110	135	255	70	14	699	125	279	180	35	275	210	180	14
D5-0290-H05	100	190	195	371	20	45	110	135	255	70	14	719	145	279	180	35	275	210	180	14
D5-0290-H05	150	190	195	371	20	45	110	135	255	70	14	747	145	279	180	35	275	210	180	14
D6-0353-H15	150	225	225	429	20	48	110	155	295	70	14	822	153	266	260	40	370	220	190	14
D6-0420-H10	150	225	225	429	20	48	110	155	295	70	14	832	163	266	260	40	370	220	190	14
D6-0420-H05	150	225	225	429	20	48	110	155	295	70	14	832	163	266	260	40	370	220	190	14
D6-0600-H05	150	225	225	429	20	48	110	155	295	70	14	857	188	266	260	40	370	220	190	14