

Levitated Magnetic Mixer

Alfa Laval MM UltraPure, Magnetic Mixer

Application

Alfa Laval magnetic mixers offer effective mixing for applications with high demands on hygienic and aseptic design.

Working principle

The patented levitated bearing makes the mixer fully drainable and able to run dry. The performance ranges from low shear mixing at around 10 rpm to high intensity mixing with vortex at up to 250 rpm. Depending on the mixer task the range covers from 30 liters to 10000 liters of nominal batch size.

Standard design

The Alfa Laval MM UltraPure mixer consists of a weld plate and a mixer unit incl. gear drive. The weld plate is ordered and delivered separately to enable early preparation of the mixer installation. The mixer must be controlled by a VFD unit matched perfectly with the mixer. The VFD is pre-programmed for optimum performance.

Any brand of locally sourced VFD may be used under observation of the mixer manual



TECHNICAL DATA

Product wetted surface finish: Ra <0.5 µm Mech. polish

Option: Ra <0.5 µm and Electro polished

*Working pressure: -1 to 7 bar (g)

- WFI 2 to 7 bar (g)

Note: Ensure liquid is below boiling temperature

Voltage and frequency

- 3x332-575V, 60Hz (Canada)

- 3x230-400V, 50Hz (ROW)

Protection class

AC motors: IP66

AC VFD stand alone: IP66

AC VFD enclosure unit: IP20

Motor sizes

MM 338-4/6: 0.37 kW

MM 434-8/10: 1.1 kW

Certificates

Standard delivery includes:

- 3.1 Materials Certificates, EN10204 for all product wetted parts
- USP Class VI <88> certificates for Zirconia YTZP and ISOLAST 9501
- FDA Declaration of conformity for elastomers and ceramics
- USDA-H1 conformity statement (FDA) for gear drive oil
- TSE declaration (Transmissible Spongiform Encephalopathy) / ADI declaration (Animal Derived Ingredients)
- USP Class VI <88> certificates on request for Silicon Carbide parts

PHYSICAL DATA

Materials

Impeller and Weld Plate: AISI 316L (UNS S31603)

Drive rotor and distance piece: AISI 316L (UNS S31603)

Motor and Gearbox: ANSI / NSF 51 compliant paint

Male Bearing: Zirconia YTZP

Male Bearing Gasket: ISOLAST 9501 (Perfluoro Elastomer)

Female Bearing: Silicone Carbide

Gearbox oil: USDA-H1

Temperature

Product mixing (10 – 250 rpm): max. 90°C

- WFI with pressure: max. 60°C

CIP (max 50 rpm): max. 95°C

SIP (0 rpm): max. 150°C

Weight

MM 338: 12 kg

MM 434: 30 kg

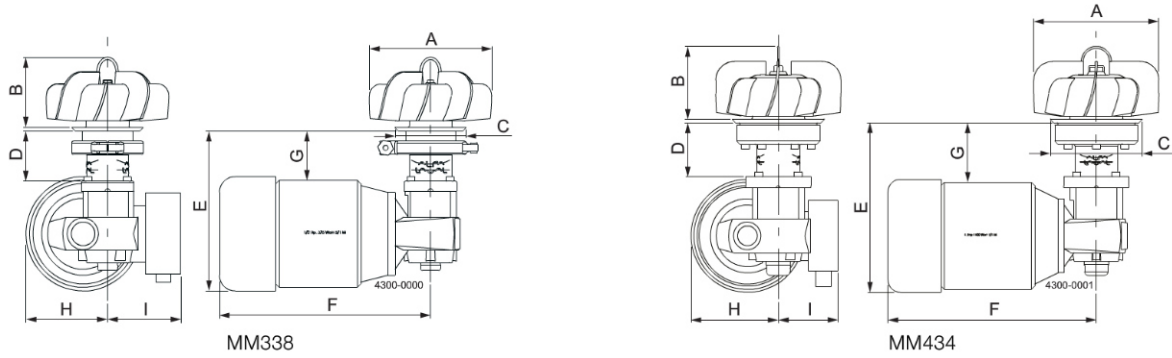
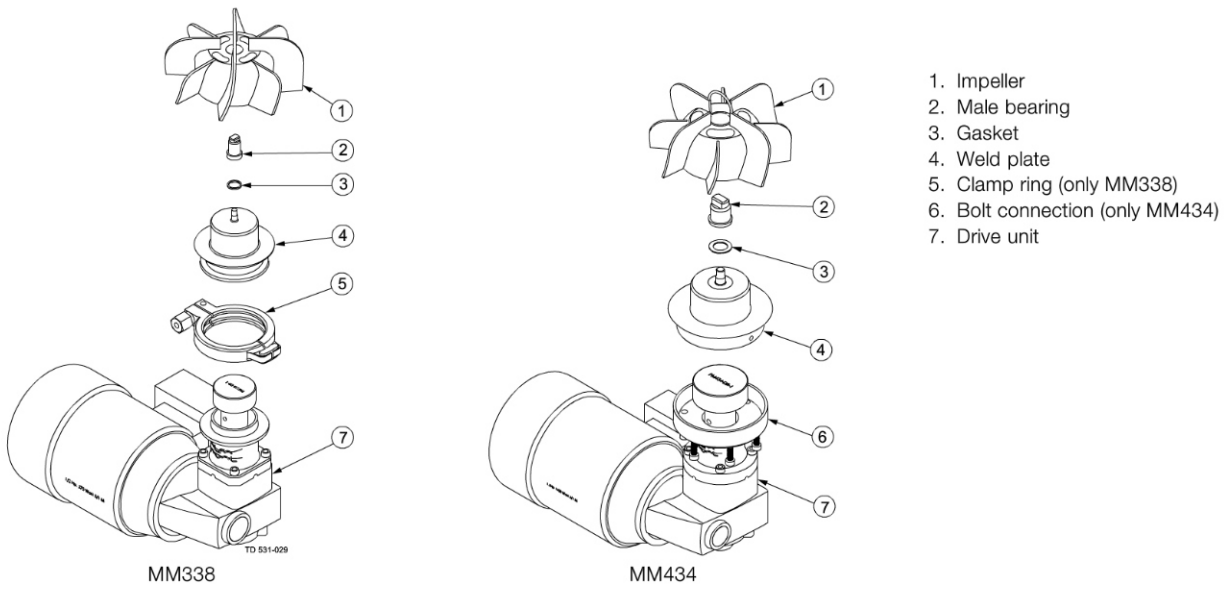

Dimensions (mm)	MM 338-4	MM 338-6	MM 434-8	MM 434-10
A	102	155	203	254
B	89	89	118	183
C	90	90	149	149
D	64	64	88	88
E	203	203	275.1	275.1
F	268	268	338	338
G	62.5	62.5	96.6	96.6
H	103.5	103.5	141.5	141.5
I	93	93	97	97

Machine Selection

Machine selection: Contact Global Technical Support, Tank Equipment