

## Superior mixing – Liquid, Gas and Powder

### Alfa Laval IM 10 Rotary Jet Mixer

The patented IM 10 Rotary Jet Mixer (RJM) does not only mix fast, efficient and uniform but creates also the necessary process flexibility that makes it easy to switch to new product formulations with diverse viscosities, densities and volumes. Besides classic liquid to liquid mixing the RJM is excellent for gas and powder dispersion plus a superb tank cleaning machine.

#### Applications

Process and storage vessels between 1-10 m<sup>3</sup> used in a wide range of industries such as: beer & beverage, food & ingredients, home & personal care, health care, biotech and chemical industry etc.

#### Operation

Secure that the mixer is positioned in the correct level and submerged into the liquid before round pumping or when adding any additional products from any up-stream pipe works.



#### TECHNICAL DATA

Lubricant: . . . . .	Self-lubricating with the mixing/cleaning fluid
Standard thread: . . . . .	1" BSP or NPT, female, Top cone 1" BSP with sanitary seal
Min. tank opening: . . . . .	See dimension drawings
Pressure	
Working pressure: . . . . .	2-8 bar
Recommended pressure during mixing: . . . . .	2-6 bar
Recommended pressure during CIP: . . . . .	4-8 bar



#### PHYSICAL DATA

Materials	
Materials: . . . . .	AISI 316L, AISI 316, SAF 2205 (UNS 31803), EPDM, PEEK, PVDF, PFA, Ceramics
Weight: . . . . .	5.1 kg
Temperature	
Max. working temperature: . . . . .	95 °C
Max. ambient temperature: . . . . .	140 °C
Certificates	
2.1 material certificate ATEX.	

#### Benefits

Using the IM 10 Rotary Jet Mixer makes it possible, at a modest investment, to perform fast and efficient mixing in a sanitary system. In traditional systems, using propeller mixers, a rotating shaft penetrates the tank wall, and a mechanical seal and a gear box are installed. With the Rotary Jet Mixer technology the shaft, seal and gearbox are eliminated, and a more sanitary design is obtained. With the Rotary Jet Mixing technology good mixing is achieved without the use of baffles. The Rotary Jet Mixer can also be used for gas dispersion. The IM 10 can furthermore be used for efficient CIP when the tank is empty, saving liquid, chemicals and energy compared to a fixed spray ball CIP system.

Flow rate

Relationship between inlet pressure and flow rate for liquids with waterlike properties for the IM 10 Rotary Jet Mixer.

Volumetric flow rate [m<sup>3</sup>/h]

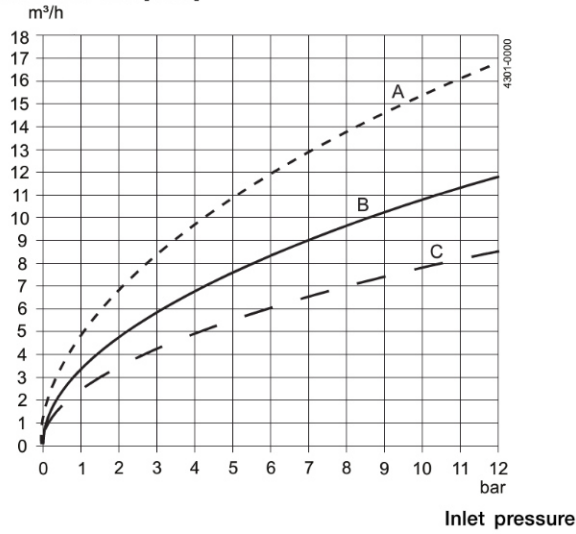

- Nozzles
- A) d = 5.5 mm
  - B) d = 4.6 mm
  - C) d = 3.9 mm

Reach of jet

Reach of jet for the IM 10 during cleaning, and indicative reach of jet for mixing of liquids with water-like properties.

Reach of jet [m]

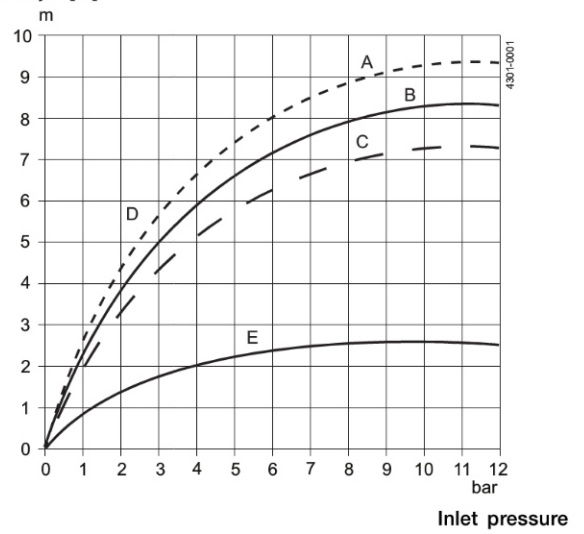

- Nozzles
- A) d = 5.5 mm
  - B) d = 4.6 mm
  - C) d = 3.9 mm
  - D) Cleaning
  - E) Mixing

Dimensions (mm)

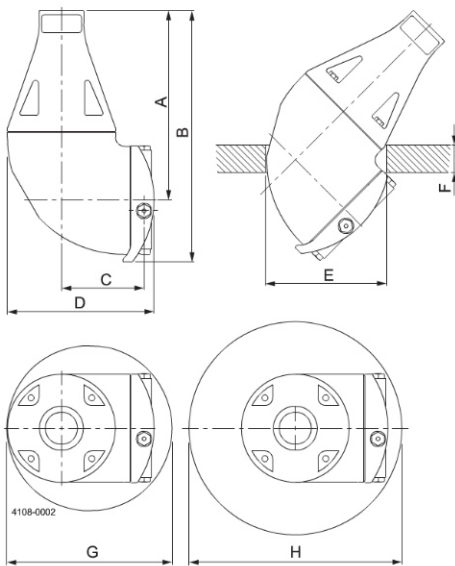

A	B	C	D	E	F	G	H
173	230	75	133	∅110	Max. 25	∅150	∅200

The Rotary Jet Mixing technology

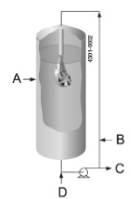

- A = Rotary Jet Mixer
- B = Gas
- C = Product
- D = Liquid feed

Traditional Mixing technology

Round pumping Propeller mixing

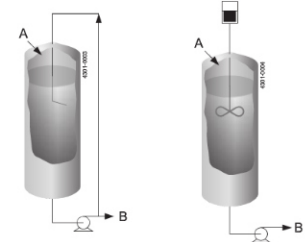

- A = Liquid feed
- B = Product